

By signing the **Customer Acceptance** on this print, I understand that I am accepting all aspects of this drawing. **X**  
 This includes Artwork, Specifications, Dimensions, Spelling, and all other representations herein.  
 I also understand that color reproductions on this print are approximate, and may not match manufactures samples exactly.

**Customer Acceptance SIGNATURE**

DATE



**IF REQUIRED: Landlord Acceptance SIGNATURE**

DATE

**L.S.G SALES INITIALS**

DATE



**Landmark Sign group**

7424 Industrial Avenue  
 Chesterton, IN 46304  
 phone 219.762.9577  
 fax 219.762.4259  
[www.landmarksign.com](http://www.landmarksign.com)

**PRINT #**  
**SL-26203-1A**

**SCOTT LOVELL**  
 LSG SALES REPRESENTATIVE

**06.04.2021**  
 DATE

**HOBART HIGH SCHOOL**  
**FCO**  
 CLIENT NAME

**2211 E. 10<sup>TH</sup> STREET**  
**HOBART, IN**  
 JOB LOCATION

LS AS NOTED  
 DRAWN BY SCALE

**REVISIONS:**

- 



**Designed for 110/277 Volts**  
 Electrical Connection will be Visible within 5 Ft. at time of Installation;  
 Second Trip will be Charged at Time & Material

**THIS DRAWING IS THE PROPERTY OF LANDMARK SIGN GROUP, INC.**  
 NO REPRODUCTIONS OR EXHIBITIONS ARE PERMITTED WITHOUT THE EXPRESS WRITTEN CONSENT OF LANDMARK SIGN GROUP, INC.  
 AN ASSESSMENT OF UP TO \$2500.00 WILL BE CHARGED FOR ANY MISUSE OF THIS DRAWING.



**BRICKIE CHAMPIONSHIP PLAZA**

Front View 1/8" = 1'-0"

**▶ TWO (2) SETS OF NON-ILLUMINATED FLAT-CUT-OUT LETTERS  
 STUD MOUNTED FLUSH TO BRICK WALL**

**● MAIN COPY = ~~3/8"~~ ALUMINUM PAINTED SATIN MAP WHITE  
 3/8"**

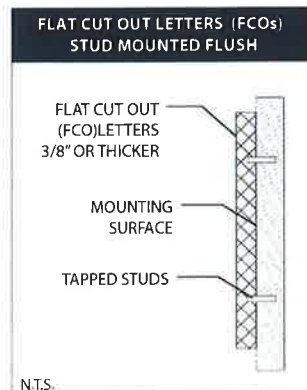

Proposed - N.T.S.

By signing the **Customer Acceptance** on this print, I understand that I am accepting all aspects of this drawing. **X**  
 This includes Artwork, Specifications, Dimensions, Spelling, and all other representations herein.  
 I also understand that color reproductions on this print are approximate, and may not match manufactures samples exactly.

**Customer Acceptance SIGNATURE**

DATE

**X**

IF REQUIRED: **Landlord Acceptance SIGNATURE**

DATE

**L.S.G SALES INITIALS**

DATE

**Landmark Sign group**

7424 Industrial Avenue  
 Chesterton, IN 46304  
 phone 219.762.9577  
 fax 219.762.4259  
[www.landmarksign.com](http://www.landmarksign.com)

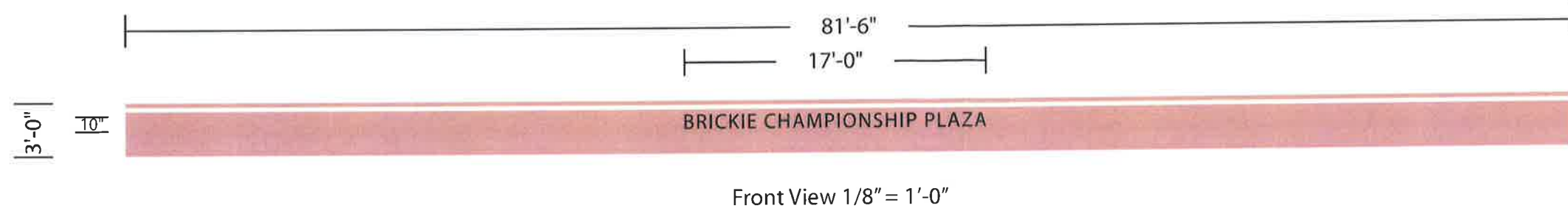

PRINT #  
**SL-26203-1**

**SCOTT LOVELL**  
 LSG SALES REPRESENTATIVE

**06.04.2021**  
 DATE

**HOBART HIGH SCHOOL**  
**FCO**  
 CLIENT NAME

**2211 E. 10<sup>TH</sup> STREET**  
**HOBART, IN**  
 JOB LOCATION

LS AS NOTED  
 DRAWN BY SCALE

REVISIONS:

- 

**▶ TWO (2) SETS OF NON-ILLUMINATED FLAT-CUT-OUT LETTERS  
 STUD MOUNTED FLUSH TO BRICK WALL**

- MAIN COPY =  $\frac{1}{4}$ " ALUMINUM PAINTED SATIN MAP BLACK  
 $\frac{3}{8}$ "

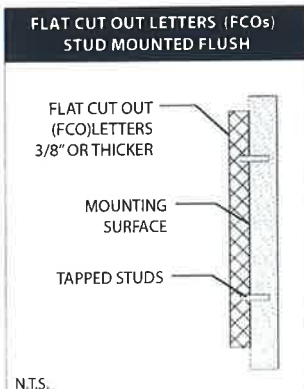

Proposed - N.T.S.



**Designed for 110/277 Volts**

Electrical Connection will be Visible within 5 Ft. at time of Installation;  
 Second Trip will be Charged at Time & Material

**THIS DRAWING IS THE PROPERTY OF LANDMARK SIGN GROUP, INC.**  
 NO REPRODUCTIONS OR EXHIBITIONS ARE PERMITTED WITHOUT THE EXPRESS WRITTEN CONSENT OF LANDMARK SIGN GROUP, INC.  
 AN ASSESSMENT OF UP TO \$2500.00 WILL BE CHARGED FOR ANY MISUSE OF THIS DRAWING.